

Mundstück PP 28-S  
nach DIN 6094-7

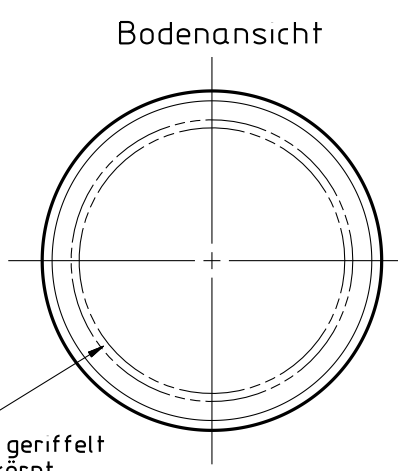
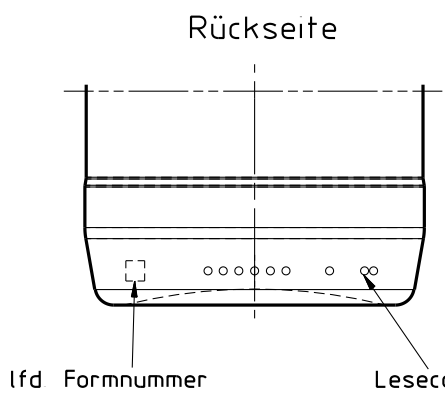
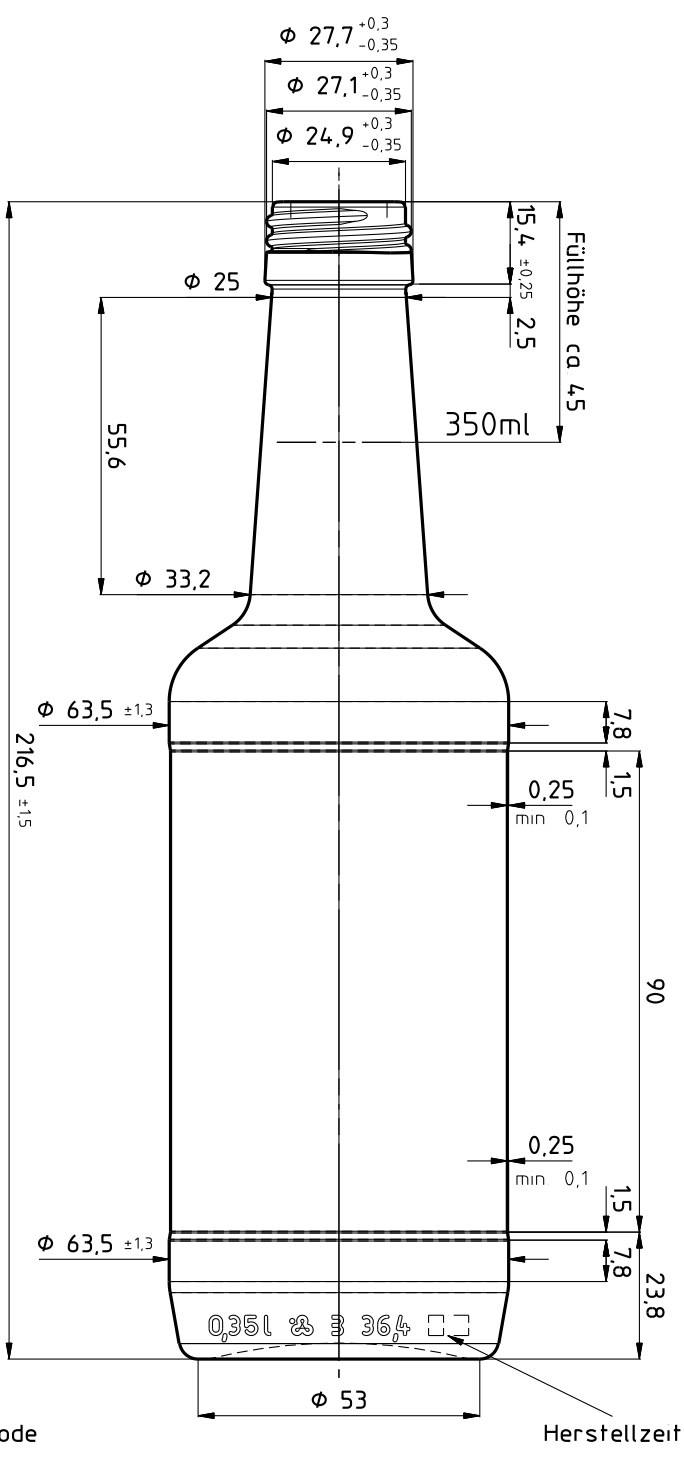

INDEX		ÄNDERUNGEN / modifications		PT. GEPRÜFT PT. approved		DAT		VIS		APRUELLTEMPERATUR Filling temperature		VOLUMEN FÜLLVOLL Capacity fillpoint		BEMERKUNG Remarks	
A		neue Artikelnummer.		FIB FREIGABE FIB released		24.0108		VIS		KONDITIONIERUNGSTEMP Conditioning temperature		VOLUMEN RANDVOLL Capacity brimfull			
1		24.0108		Mes		24.0108		VIS		CO <sub>2</sub> GEHALT CO <sub>2</sub> content		GLASGEWICHT CA Approx. glass weight		ÄHNLICH WIE Similar to	
2						24.0108		VIS		ALKOHOLGEHALT Alcohol content		MITTL. WANDDICKERE Average wall thickness		ERSATZ NR Replace No	
3						24.0108		VIS		KOPFDRUCK Axial pressure		HALTSANSCHLUSS-D Neck connection dia		OFFERT-NR Offer No	
4						24.0108		VIS		VERWENDUNG Disposal		HALTSCHNITT-D Neck diameter		OFFERT-NR Offer No	
5						24.0108		VIS		PROZESS Process		HALTSCHNITT-D Neck diameter		OFFERT-NR Offer No	
6						24.0108		VIS		PROZESS Process		HALTSCHNITT-D Neck diameter		OFFERT-NR Offer No	
7						24.0108		VIS		PROZESS Process		HALTSCHNITT-D Neck diameter		OFFERT-NR Offer No	
8						24.0108		VIS		PROZESS Process		HALTSCHNITT-D Neck diameter		OFFERT-NR Offer No	
9						24.0108		VIS		PROZESS Process		HALTSCHNITT-D Neck diameter		OFFERT-NR Offer No	
10						24.0108		VIS		PROZESS Process		HALTSCHNITT-D Neck diameter		OFFERT-NR Offer No	