

Rückansicht / back view

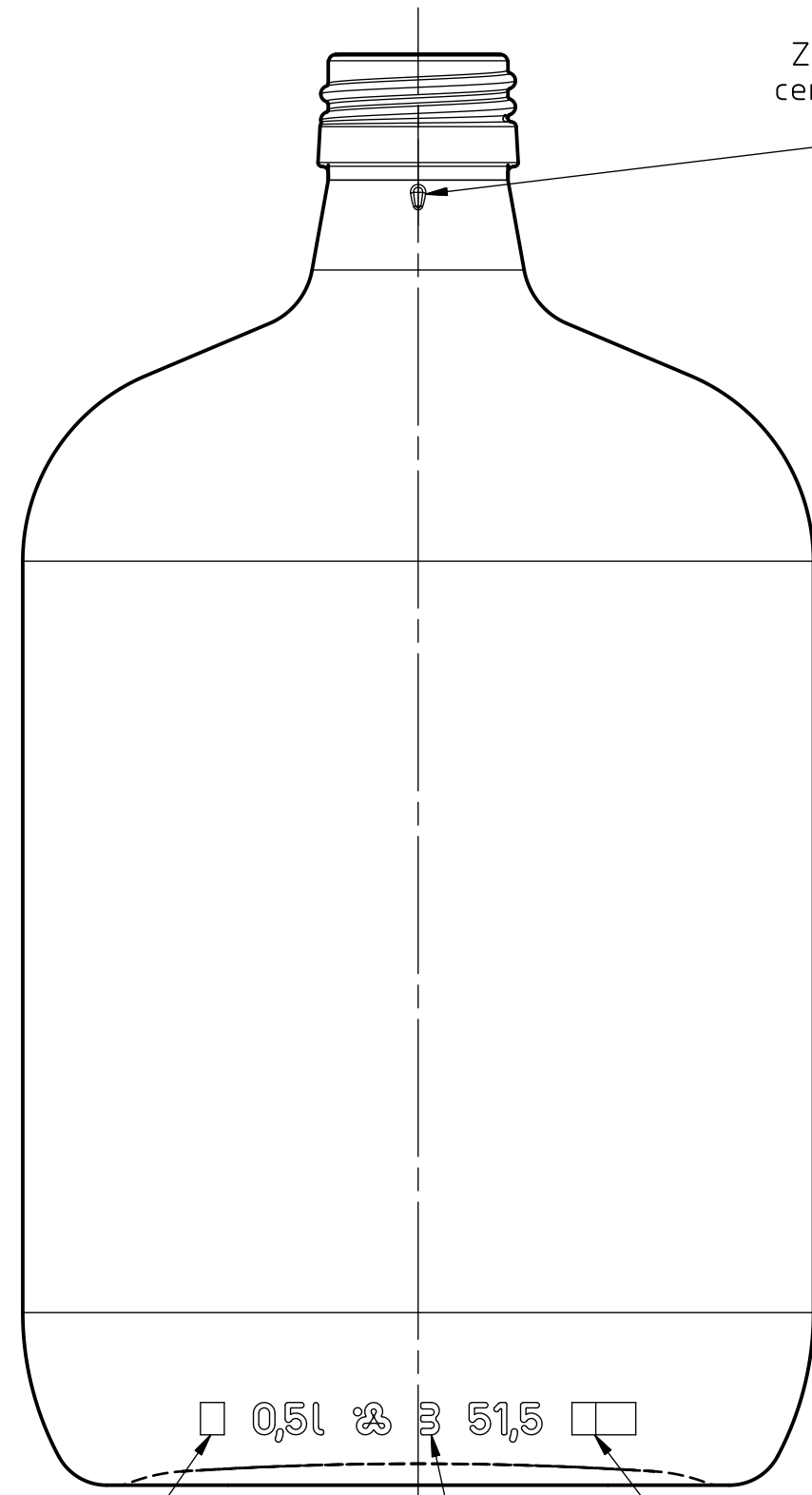

lfd. Formnummer
mould number

Herstellzeit
manufacture mark

Bodenansicht / bottom view

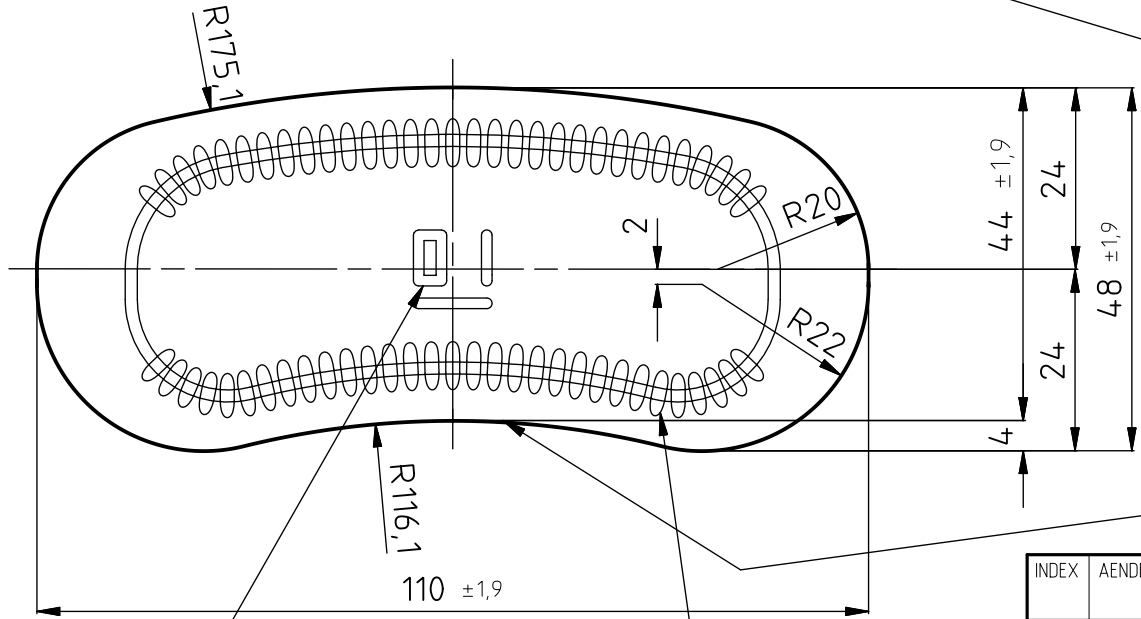

Klarschriftleseeode
mould code

Standfläche mit Wellenriffelung
bearing surface stippled

Gravur auf dieser Seite
engraving on this side

Seitenansichtansicht / side view

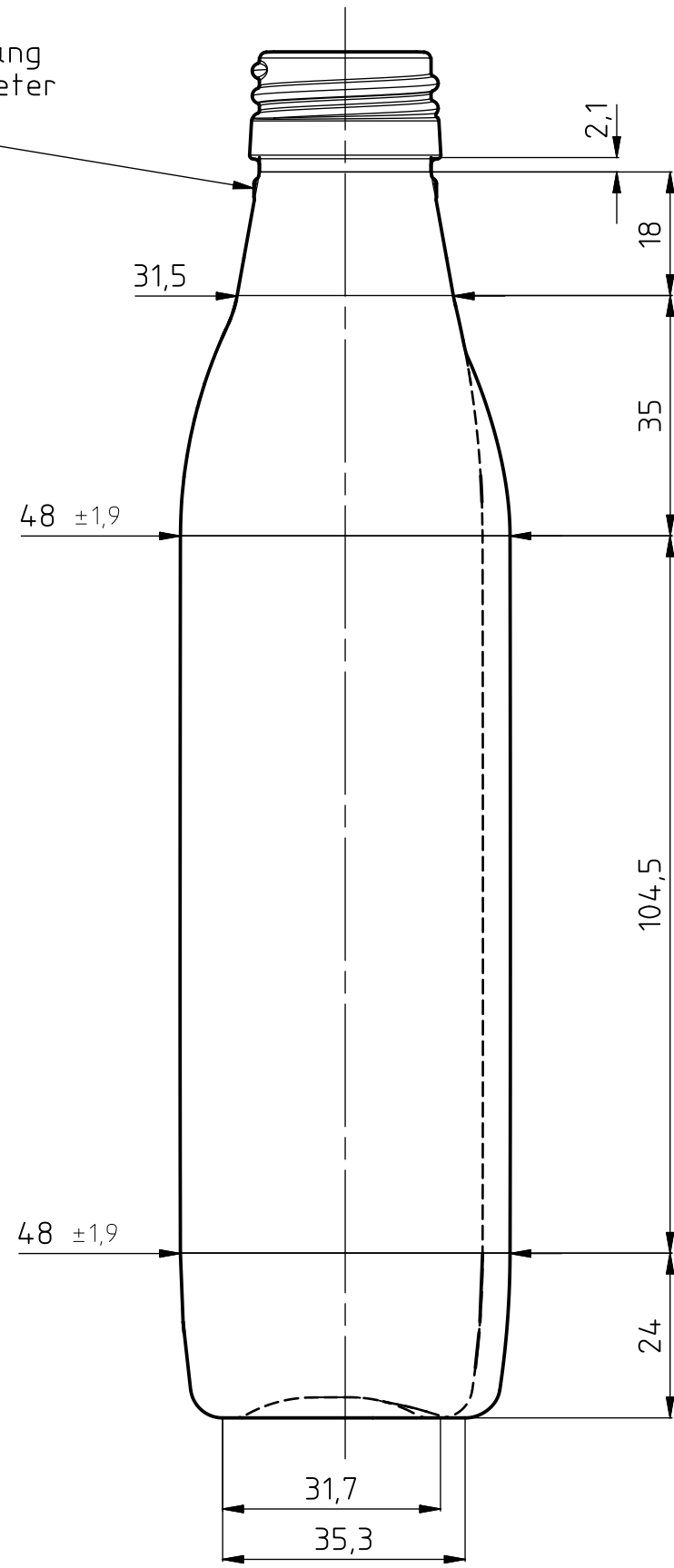

Vorderansicht / front view

Mundstück PP 28 S
nach DIN 6094-7

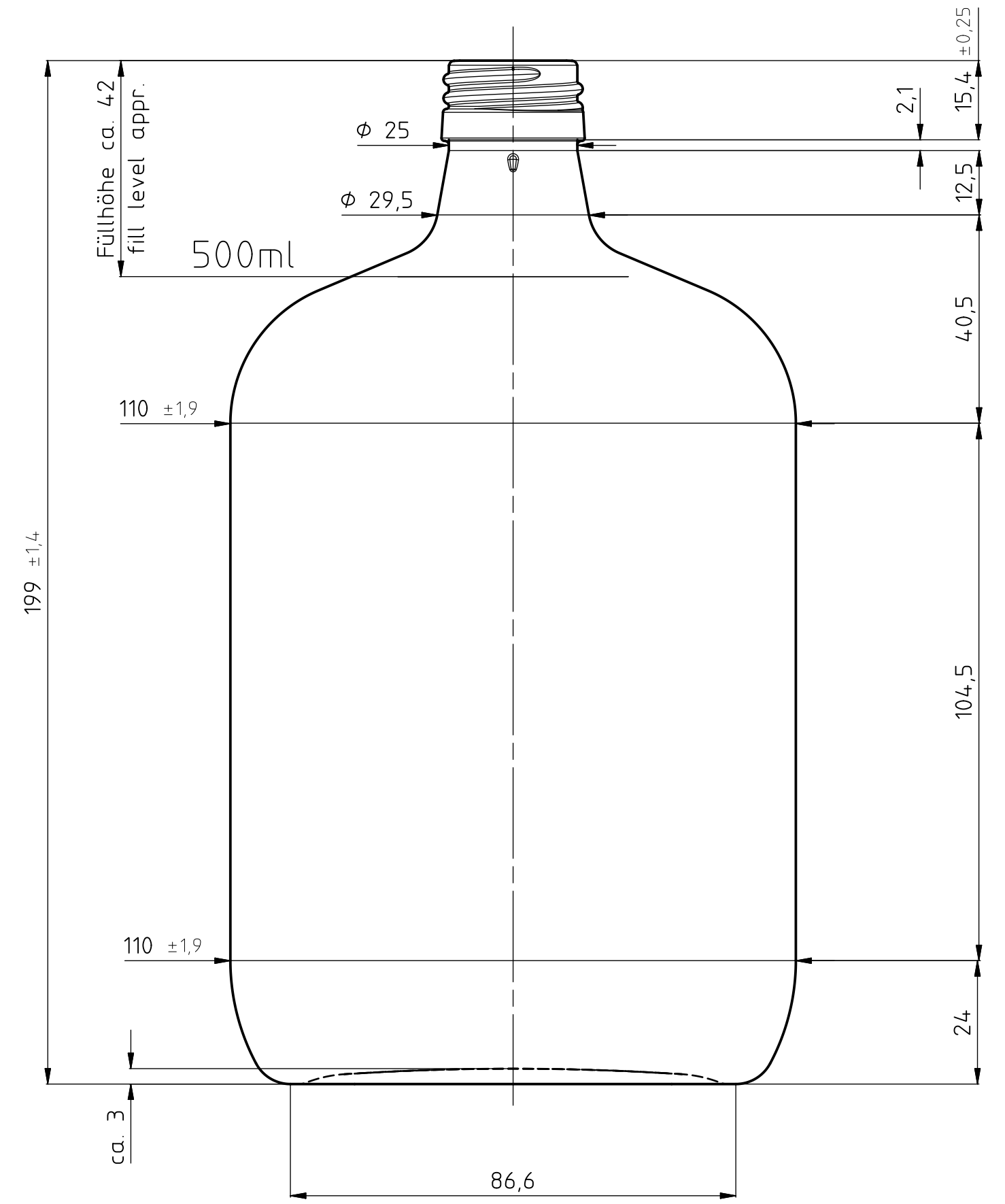

We declare our agreement with this drawing and the stated tolerances and hereby give our "Good for Execution".

04.01.21 Ht POE

INDEX	ÄNDERUNGEN / modifications		DAT	NAME	PT GEPRUEFT PT approved	DAT 22.12.20	VIS Mes	ABFUELLTEMPERATUR Filling temperature	≤ °c	VOLUMEN FUELLVOLL Capacity fillpoint	500 ml ± ml	BEMERKUNG Remarks	WF 2035							
	FHB FREIGABE FHB approved	WERK POE	DAT 22.12.20	VIS Mw	KONDITIONIERUNGSTEMP Conditioning temperature	≤ °c	VOLUMEN RANDVOLL Capacity brimful	515 ml ± 10 ml	KUNDE Customer	Standard										
	FS FREIGABE FS approved	WERK POE	DAT 23.12.20	VIS Fha	ALKOHOLGEHALT Alcohol content	≤ Vol%	MITTL WANDSTAERKE Average wall thickness	3,51 mm	ERSETZT NR Replace No	03224.0500	Zei. Nr 4914									
NICHT TOLERIERTE MASSE NACH NORM DIN 6129 dimensions without tolerances conform to standard DIN 6129					KOPFDRIUCK Axial pressure	daN	HALSANSCHLUSS-D Neck connection dia	25 mm	OFFERT-NR Offer No											
					VERWENDUNG Disposal	MW	AW	EW	X	HALSDURCHGANG-D MIN Min through bore	16 mm	MASSTAB Scale	1.1							
					PROZESS Process	BB	PB	EPB		FARBE Color		GEZ Des	Kru	DAT 21.12.20	DATEITYP Filetyp	AZ	ARTIKEL-NR Item No	4S021.0500.3782	INDEX	A

vetropack

Vetropack Austria GmbH
AT-3380 Poechlarn
Tel: 0043-27 57 75 41
www.vetropack.com

BEZEICHNUNG
Designation
Flask Tafla 430g PP2815 500ml
PP

ARTIKEL-NR
Item No

VPK-0715-01-F08-086-DE-EN